

SPECIFICATIONS		
Table Diameter	φ250 mm	
0° Height	235 mm	
90° Center Height	224 mm	
Table Inner Dia.	φ95 mm	
Spindle Through Hole Dia.	φ70 mm	
Clamp Method	Pneumatic	
Allowable Work Inertia	1.95 kgm ²	
Clamp Torque	750 Nm	
Max. Spindle Speed	33.3 RPM	
Gear Ratio	Tilt Axis	1 / 72
	Rotate Axis	1 / 90
Repeatability Accuracy	20 sec	
Indexing Accuracy	4 sec	
Weight	125 kg	
Servo Motor	YASKAWA SGM7P-15A7A6S	

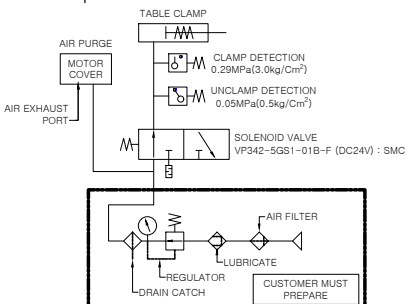

Servo motor : SGM7P-15A7A6S

TITLE	ROTRARY MANUAL TILTING	REV	01	02	03
DRW. NO.	RTM-25014-V1.0-00	USER			
CODE NO.		REV			
PROJECT		DEVELOPER	Research & Development		
		DATA			